

Familial hypercholesterolaemia

Blom DJ, MBChB (UCT), FCP (SA), MMed (UCT), PhD (UCT)

Division of Lipidology, Department of Medicine, University of Cape Town, South Africa

Correspondence to: Dirk J Blom, e-mail: dirk.blom@uct.ac.za

Keywords: familial hypercholesterolaemia; low-density lipoprotein receptor; apolipoprotein B100; PCSK9; tendon xanthomata

Abstract

Familial hypercholesterolaemia (FH) is a monogenic disorder of low-density lipoprotein (LDL) metabolism. It is characterised by markedly elevated LDL cholesterol, autosomal dominant inheritance, premature cardiovascular disease and tendon xanthomata. FH is a genetically heterogeneous disorder, but the most common underlying molecular cause is mutation of the LDL receptor gene. The worldwide prevalence of FH is 1:500. South Africa has three founder populations in which the prevalence of FH may be as high as 1:70. FH is diagnosed clinically, but the diagnosis can be confirmed by DNA analysis. DNA testing cannot always identify the causative mutation because there are several genes to examine and more than 1 500 different mutations have been identified in the LDL receptor alone. Statins are the treatment of choice for patients with FH. Ezetimibe or cholestyramine can be added if additional LDL lowering is required, or if patients are unable to tolerate high statin doses.

© Peer reviewed. (Submitted: 2010-07-26, Accepted: 2010-09-26). © SAAFP

S Afr Fam Pract 2011;53(1)11-18

Introduction

Familial hypercholesterolaemia (FH) is probably the most common monogenic disorder that the general practitioner is likely to encounter. Worldwide the prevalence is estimated to be around 1:500, but in populations with a founder effect (see below), the prevalence may be as high as 1:70.¹ FH, however, remains seriously underdiagnosed and undertreated. In the UK, it is estimated that more than 80% of FH patients remain undiagnosed.² Early detection and treatment of FH may save many lives because up to 30% of patients do not survive an initial myocardial infarction (MI). Although there are no accurate South African statistics, the local situation is not likely to be much different. What distinguishes South Africa from the UK is that, as a result of founder effects, there are three ethnic communities in which FH is highly prevalent. FH is thus even more relevant in South Africa. The challenge to all of us is not only to identify and treat the index patient, but also to screen families whenever possible.

Familial hypercholesterolaemia

FH is a clinically defined syndrome. The key diagnostic elements are a family history of autosomal dominant low-density lipoprotein (LDL) hypercholesterolaemia, premature cardiovascular disease and tendon xanthomata. FH is a monogenic disorder; mutation of a single gene is sufficient to cause the phenotype. Thus far, four genes that cause FH

have been identified. The diagnosis of FH is clinical, but the causal gene can only be identified by genetic testing.

FH phenotypes

Some of the genes linked to FH display a gene dose effect, with a much more severe phenotype (homozygous FH [hoFH]) when both alleles of the gene are mutated ('double dose'). Heterozygous FH (heFH) results from a single mutated allele ('single dose') and is far more common than hoFH.

Heterozygous FH

The LDL cholesterol (LDLC) in heFH is usually between 5 and 12 mmol/L. At the Groote Schuur Hospital (GSH) Lipid Clinic, the median LDLC in untreated patients with definite FH was 6.95 mmol/L but, as Figure 1 shows, there is a wide range of LDLC values. The prevalence of tendon xanthomata and other physical stigmata of hyperlipidaemia increases with age (Figure 2). About 93% of patients will develop tendon xanthomata (Figure 3) during their lifetime.³ HeFH is associated with a markedly increased risk of death from ischaemic heart disease (IHD). The increased risk of death is highest in young patients. Data from the Simon Broome FH Registry, collected mainly in the pre-statin era, show a standardised mortality ratio (SMR) for IHD in the 20–39-year-old cohort of 9 686 (95% confidence interval 3 670–21 800).⁴ Comparing this with the SMR of 100 in a control population reveals just how enormous the increased risk associated with FH is.

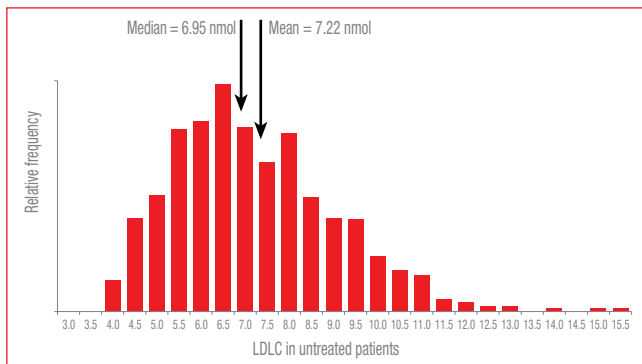

Figure 1: LDLC distribution in untreated FH patients at the GSH Lipid Clinic. The median LDLC is 6.95 mmol/L with a mean LDLC of 7.22 mmol/L.

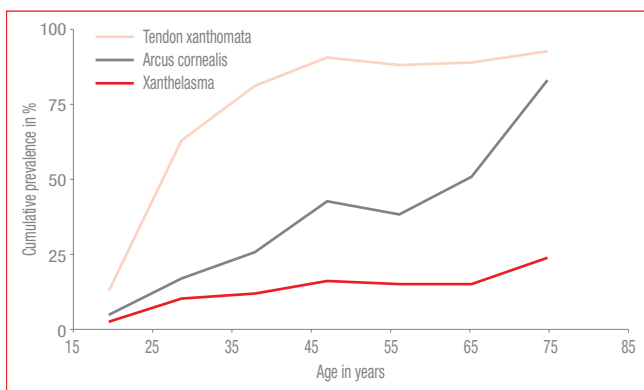

Figure 2: Cumulative prevalence of physical signs in adult FH patients at the GSH Lipid Clinic. The prevalence of arcus cornealis increases almost linearly with age while the prevalence of tendon xanthomata increases most rapidly in the 20–45-year age group.



Figure 3: Achilles tendon xanthomata in a patient with heterozygous FH. The Achilles tendons are markedly thickened and irregular.

Homozygous FH

The LDLC in hoFH is usually > 12 mmol/L, and often significantly higher. Skin and tendon xanthomata usually develop before the age of 10 years. Planar xanthomata (Figure 4) and interdigital xanthomata (Figure 5) in infants and toddlers often are the first clue to the diagnosis. IHD, which may be fatal, is common in children or adolescents. Lipid deposition in the ascending aorta often causes supravalvular aortic stenosis that may require aortic valve and root replacement.



Figure 4: Planar xanthoma in a patient with homozygous FH. There are multiple cutaneous deposits of cholesterol in this patient.



Figure 5: Interdigital xanthomata in a patient with homozygous FH. Interdigital xanthomata are pathognomonic of homozygous familial hypercholesterolaemia.

Genes linked to FH

The primary lipid abnormality in FH is marked elevation of LDLC. LDL is the primary atherogenic lipoprotein in humans, and also transports the bulk of plasma cholesterol. Most plasma LDL is generated in the circulation from hepatically secreted very low-density lipoproteins (VLDL) following lipolytic processing. Most cells can take up LDL if they require cholesterol, but hepatic LDL uptake determines plasma LDL concentration. The liver removes LDL from the circulation via the LDL receptor (LDLR) and malfunction of

this system with defective clearance of LDL causes LDL to accumulate. All of the genes that have thus far been linked to FH interfere with LDL clearance, either directly or indirectly.

LDLR

The LDLR was the first gene linked to FH. Mutations of the LDLR are by far the most common molecular cause of FH. Brown and Goldstein discovered the LDLR in a series of groundbreaking experiments and were awarded the 1985 Nobel Prize for their work. Their discovery was not only crucial to understanding FH, but was also one of the first demonstrations of receptor-mediated endocytosis, a process critical to understanding cell biology.⁵

The LDLR is located on chromosome 19 and has 18 exons. Thus far, more than 1 500 different mutations have been identified in the LDLR. At the GSH Lipid Clinic, 64 different LDLR mutations have been documented thus far, and many more are likely to be found by systematic screening of our cohort of FH patients for LDLR mutations.

Founder populations are characterised by a high prevalence of FH, with one or a few LDLR mutations explaining a large proportion of cases. South Africa has three populations in which founder effects are seen. The most common LDLR mutations (the amino acid change in the LDL protein is indicated) are listed in brackets:

- White South Africans of Afrikaner descent (D206E, V408M and D154N).
- Jewish South Africans of Lithuanian descent (deletion G197).
- Indian South Africans of Gujerati descent (P664L).

Apolipoprotein B100

Each LDL particle contains one apolipoprotein B100 (apo B100) molecule, which forms the structural backbone of the lipoprotein. Binding of LDL to the LDLR occurs exclusively via apo B100. Mutations in the binding region of apo B100 decrease its affinity for the LDLR and reduce LDL clearance.

There is no local founder effect for apo B100 mutations and less than 1% of patients with a clinical diagnosis of FH at the GSH Lipid Clinic have identified apo B100 mutations. The most common apo B100 mutation (R3500Q) is thought to have originated in central Germany, with its subsequent distribution tracking the migration of Celtic tribes.⁶ FH due to mutations in apo B100 is sometimes also called familial defective binding apo B100 (FDB).

PCSK9

Proprotein convertase subtilisin/kexin type 9 (PCSK9) is a relatively recently discovered protein that down-regulates LDLR activity.⁷ PCSK9 differs from the genes described above in that both gain-of-function and loss-of-function mutations have been described. Mutations that increase PCSK9 activity impair LDLR activity and cause FH. Loss-

of-function mutations are associated with low LDLC levels and low rates of cardiovascular disease.⁸ In Cape Town, one family with FH secondary to a PCSK9 gain-of-function mutation has been found.

Autosomal recessive hypercholesterolaemia

The autosomal recessive hypercholesterolaemia (ARH) protein is an adaptor protein that is critical to the functioning of the LDLR in hepatocytes. Heterozygous mutations in ARH are not associated with hypercholesterolaemia, but homozygous mutations lead to a hoFH phenotype. There is currently one known ARH patient in South Africa. Most of the patients diagnosed worldwide with ARH originate from Sardinia.⁹

Clinical genetics of FH

LDLR mutations

The inheritance of FH is autosomal dominant. Mutation of one of the two alleles of the LDLR (heterozygous state) is sufficient to cause the phenotype. Patients with two mutated alleles have hoFH and a much more severe phenotype. The risk of inheriting the disorder from the affected parent is 50% for each child if the parent has heFH. If both partners have heFH, there is a 25% chance of having a child with hoFH, a 50% chance that the child will be heterozygous and a 25% chance that the child will not have inherited hypercholesterolaemia. The children of a homozygous parent are obligate heterozygotes, as they can only inherit a mutated allele from their affected parent. Should the other parent be a heterozygote, the risk of homozygosity for the children is 50%.

The disorder does not skip generations and is not sex linked; men and women are affected with equal frequency. Some common misconceptions about the genetics of FH include the following:

- Men are affected more frequently than women.
 - As cardiovascular disease occurs earlier in men than women, it is often more dramatically premature, creating the impression that FH is more common in men.
- A child will only inherit the condition if he or she is of the same gender as the affected parent.
 - This is a misunderstanding of the genetics of FH; there is no sex-linked inheritance.
- If a couple, in which one partner has heFH, has two affected children, the third child is likely to be unaffected.
 - Although statistically 50% of the children of this couple will be affected, each conception 'flips the genetic coin' afresh, unaffected by previous results. The chance that the third child will be a heterozygote therefore remains 50%.
- Patients that do not come from founder populations do not have/cannot have FH. The diagnosis of FH is, for instance, often not considered in black South Africans as

FH is viewed as a disease exclusive to white Afrikaners.

- There is no founder effect in black South Africans, but FH still occurs at the worldwide prevalence of 1:500.

Apo B100 mutations

This is also an autosomal dominant condition and the same considerations as for LDLR mutations apply, except that there is no gene dose effect and patients with two mutated alleles (homozygosity) do not have a much more severe phenotype than heterozygous patients.¹⁰ This is likely due to increased clearance of LDL precursor lipoproteins by the up-regulated LDLR.

PCSK9

The inheritance of PCSK9 is also autosomal dominant. Homozygosity for gain-of-function hypercholesterolaemic mutations has not been described thus far. Homozygous or compound heterozygote loss-of-function mutations are associated with very low LDLC without other adverse effects.¹¹

ARH

ARH is a recessive condition. Heterozygotes are clinically normal and homozygotes have the hoFH phenotype.

Diagnosing FH

Family history

Obtaining a detailed family history takes a few minutes, but the time invested is definitely worthwhile. A well-taken family history is very useful in elucidating the inheritance pattern of hyperlipidaemia and identifying other family members potentially at risk.

The easiest way to record the family history is by drawing a family tree (see Figure 6 for an example), which should include as many generations as possible. Most patients can provide information on at least three generations (index patient, parents and grandparents), and a fourth generation can be added if the index patient has children. As much as possible, relevant information is then added to the family tree. When FH is the primary focus, important details would include the following:

- Surnames and maiden names (women);
- Geographical and ethnic origin;
- Age and cause of death for all deceased family members;
- Lipid values or treatment for hypercholesterolaemia;
- Major medical diagnoses in family members;
- Age at which cardiovascular disease, if present, first became manifest.

Figure 6: Family tree of an FH family.

The index patient was referred for assessment of cardiac transplantation, as he had developed severe heart failure following multiple MI. The family tree shows that there are still multiple unscreened relatives, including the children of the index patient.

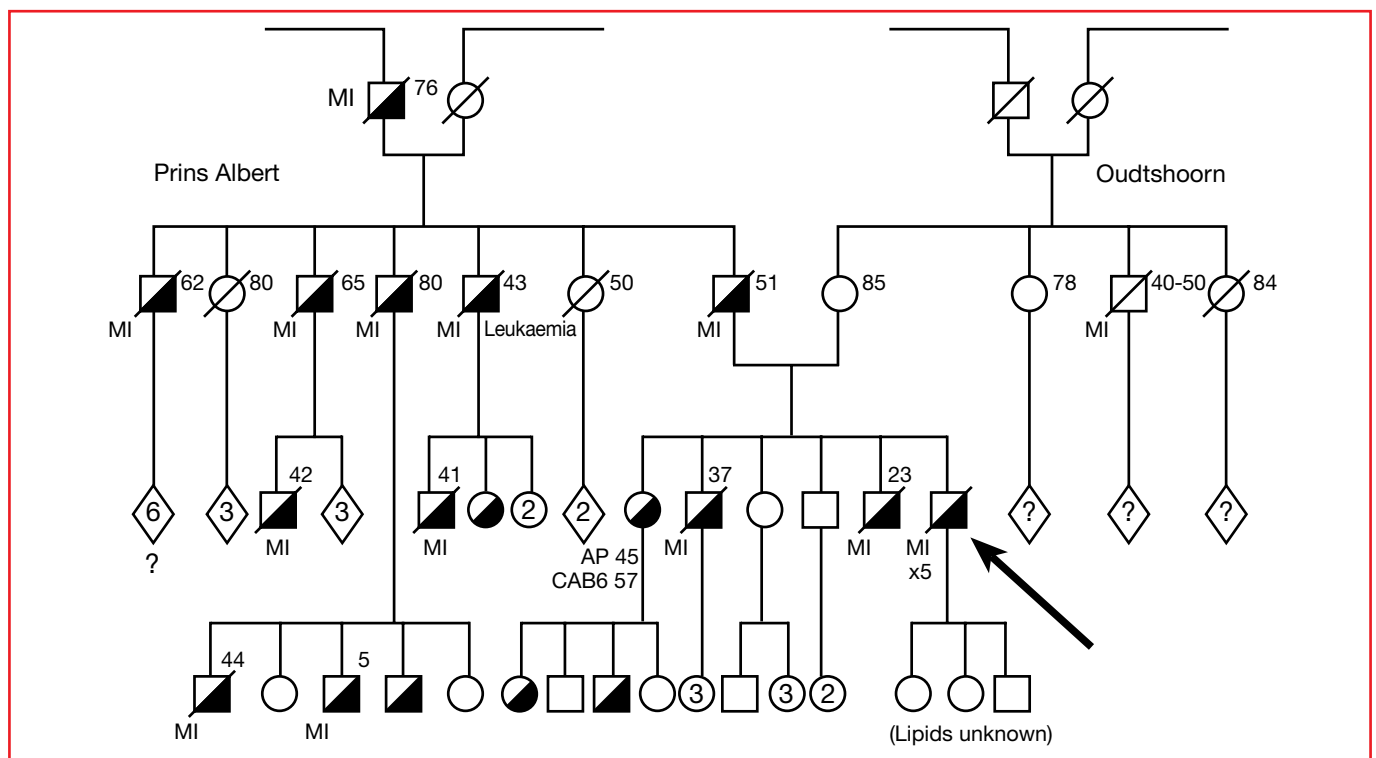

The index patient is indicated with an arrow. Men are represented by squares and women by circles. Deceased individuals are indicated by a diagonal line drawn through the symbol. Half-shading is used to indicate proven or inferred heFH

Note: This is an original family tree that has been redrawn to increase clarity. Names have been removed to ensure confidentiality and minor edits have been made for illustrative purposes.

Documenting surnames and maiden names often allows one to link patients into families with FH already known to the clinic. In many cases, patients are not aware of the link and may even meet 'new' relatives in the waiting room. Details on geographic and ethnic origin are useful in identifying whether there are any potential links to founder populations. Medical and lipid details are useful in judging the likelihood of the family member having FH. Because cardiovascular disease remains the most common cause of death, simply stating that there is a 'family history of cardiovascular disease' is of little diagnostic value. This would equally apply if the grandfather died of a an MI when he was 86 years old, or if the father had his first MI at age 28 and died at 32. The latter history of premature cardiovascular disease is clearly more relevant. Premature cardiovascular disease is somewhat arbitrarily defined as cardiovascular disease occurring before 55 in men, and before 60 in women. The amount and accuracy of detail that patients can provide obviously varies widely, but even a relatively sparse family tree may be helpful.

Clinical examination

Tendon xanthomata

The tendon xanthoma is the cardinal physical sign of familial hypercholesterolaemia. Tendon xanthomata result from deposition of lipoproteins within tendons following microvascular trauma. The Achilles tendon is the most commonly affected tendon, followed by the extensor tendons of the hand, but xanthomata are occasionally found in other tendons. Large Achilles xanthomata may be obvious on inspection, but smaller xanthomata are best detected by palpation. Occasionally one may not feel a discrete nodule, but rather a more general thickening and rounding of the usually elliptical Achilles tendon. In the hands, extensor tendon xanthomata are firm, non-compressible nodules that move with the tendon. Many patients with FH can recall episodes of Achilles tendonitis, often after unaccustomed exercise.

Tendon xanthomata are always pathological and clinically important. In clinical practice the vast majority of patients with tendon xanthomata will have FH. Patients with dysbetalipoproteinaemia (type III hyperlipidaemia), a genetic disorder of remnant lipoprotein metabolism, occasionally have tendon xanthomata. Dysbetalipoproteinaemic patients have a severe mixed hyperlipidaemia, and the ratio of total cholesterol to triglycerides often approximates 2:1. Phytosterolaemia and cerebrotendinous xanthomatosis are two very rare disorders of sterol metabolism in which large tendon xanthomata are a prominent feature. Patients with unexplained tendon xanthomata should be referred to a lipid clinic for further investigation.

Arcus cornealis

As a clinical sign, arcus cornealis is of limited usefulness. It is not specific for FH and the prevalence rises with age,

even in those without hyperlipidaemia. Arcus cornealis in a patient under 45 is suggestive of significant hyperlipidaemia.

Xanthelasma

Xanthelasma are not diagnostically useful, but often are of major cosmetic concern. Many patients with xanthelasma do not have significant hyperlipidaemia.

Diagnostic assessment

The diagnosis of FH is easy in hypercholesterolaemic individuals with a positive family history of autosomal dominant hypercholesterolaemia and premature cardiovascular disease who have tendon xanthomata on examination. Many patients, however, do not present with a 'full house' of clinical features, and diagnosis can then be more challenging. Diagnostic problems may, for instance, occur in younger patients who have not yet developed tendon xanthomata, in patients with incomplete family information, when premature death from other causes prevents cardiovascular disease from manifesting in the family, or when paternity is doubtful.

Several groups have developed clinical diagnostic tools for use in FH. These tools include the Dutch Lipid Clinics Network criteria, the MedPed criteria and the Simon Broome Registry criteria. These diagnostic tools all evaluate the family history, the presence of tendon xanthomata, and laboratory results to assess the likelihood of the patient's having FH. The Dutch Lipid Clinics Network criteria, illustrated in Table I, classify patients as having 'definite', 'probable' or 'possible' FH.¹²

Table I: Tendon xanthomata or arcus cornealis present before age 45 years

Family history (first-degree relative)	Premature cardiovascular disease (M < 55; F < 60)		1
	LDLC > 95 th centile for age and sex	Adult relative	1
		Relative < 18 years old	2
	Tendon xanthomata or arcus < 45		2
Clinical	Vascular disease	Patient has premature IHD	2
		Patient has premature peripheral or cerebrovascular disease	1
	Examination	Tendon xanthoma found	6
		Arcus cornealis present before age 45 years	4
Laboratory	LDLC	LDLC > 8.5 mmol/L	8
		LDLC: 6.5–8.4 mmol/L	5
		LDLC: 5.0–6.4 mmol/L	3
		LDLC: 4.0–4.9 mmol/L	1
	DNA analysis	DNA testing confirms pathogenic mutation in LDLR, or other gene related to heFH	8

Scoring

> 8 points: definite FH

6–8 points: probable FH

3–5 points: possible FH

Note: These criteria apply to adults and not children.

Differential diagnosis

Familial combined hyperlipidaemia (FCH) is the most common genetic differential diagnosis. FCH is also an autosomal dominant disorder, but the underlying genetic abnormality has not yet been conclusively identified. The prevalence may be as high as 1:100. The phenotype is characterised by an excess of apo B-containing lipoproteins. This may manifest as excessive LDL, excessive VLDL or a combination of both. Tendon xanthomata do *not* occur. There is no diagnostic test for FCH, and definite diagnosis requires lipid information from multiple family members.

Secondary causes of severe LDL hypercholesterolaemia include hypothyroidism, nephrotic syndrome, obstructive liver disease and drugs. Secondary causes should always be excluded.

Genetic testing

The initial diagnosis of FH remains clinical, but genetic testing can identify the affected gene and pinpoint the mutation. It is not essential to do genetic testing, as patients can be managed clinically. Identification of a pathogenic mutation in an FH gene confirms the diagnosis. Once the mutation has been identified in a family, it is easy to screen other members of the family with DNA testing. Prenatal diagnosis of hoFH is also possible in at-risk families with known mutations.

Genetic testing is, however, not without problems. In patients with heFH there are three genes to screen, with more than 1 500 possible mutations in the LDLR alone. A 'negative' genetic test therefore does not mean that the patient does not have FH; the mutation may simply not have been tested for. Most laboratories will only test for a few common mutations, although some European laboratories now routinely sequence the LDLR if no common mutations are found in the initial screening phase. Such an approach requires the state to commit significant resources towards identification and treatment of FH. There is little state or medical funder support in South Africa for identifying and treating FH. Genetic testing should ideally be done at lipid clinics where there is close co-operation between clinicians and the laboratory.

Management

Managing FH requires the clinician to pay attention to two distinct aspects: individual patient management to reduce cardiovascular risk and management of the family at risk.

Treating the individual

The risk of cardiovascular disease in FH patients is many times higher than in the population average. Premature cardiovascular disease is common even in the absence of other risk factors. Cardiovascular risk in FH is largely driven

by the very high LDLC, and treatment strategies thus focus on LDLC reduction and avoidance or management of other risk factors.

All patients with FH should be given advice on a healthy lifestyle. Regular exercise should be encouraged and smoking strongly discouraged. There is no set 'diet' for patients with FH; instead, patients should receive education about the principles of a healthy diet and how to preferentially choose healthy foods. A dietitian will evaluate the patient's diet, provide education and indicate healthy choices amongst the foods routinely consumed by the patient. Ideally the entire family, including family members that do not have FH, should adopt healthy eating habits. All will benefit and nobody will feel disadvantaged by having to eat 'special' food. Occasionally one encounters 'dietary nihilism' amongst patients with FH: "My cholesterol is genetic and diet will not make a difference." Although diet will not normalise the LDLC in FH, it can often lower LDLC by about 1.0 to 1.5 mmol/L. A healthy diet has many other additional health benefits that are independent of LDLC lowering. Omega-3 fatty acid supplementation has, for instance, been shown to reduce the risk of death in patients post-MI.¹³

Patients with FH are generally asymptomatic until atherosclerotic complications set in. Drug treatment can thus not improve their sense of well-being; if anything, they may feel less well if they develop side-effects. Stopping the drug does not provoke symptoms, as for instance in a patient with asthma who stops using inhalers, yet lifelong compliance is necessary. Achieving long-term dietary and drug adherence can thus be quite challenging. Strategies that may improve adherence include patient education, regular review of therapy and supporting patients when medical funds decline requests for appropriate therapy.

Risk assessment

Conventional cardiovascular risk assessment (Framingham) is inappropriate and dangerous in FH. Risk assessment algorithms are designed to cater for the majority of the population with risk factors in the usual range; they do not work when a single risk factor, such as LDLC in FH, is markedly elevated. See Box 1 for an example of how inappropriate risk calculation in FH is. Unfortunately, many medical funds still request risk calculation, although the prescribed minimum benefit (PMB) algorithm for hyperlipidaemia makes provision for FH treatment without risk calculation. Patients are, however, still being denied treatment to which they are entitled. Sometimes, this is intransigence on the part of the medical aid, but at times medical practitioners also fail to identify and label FH as such and funding requests are thus declined.

Box 1: Framingham risk equation and FH

Mr Smith attends your practice for risk evaluation. He is feeling well and has no prior history of cardiovascular disease or diabetes. He is on no medication. He is worried because his father died of a MI at age 44 and he is now approaching that age. His details are as follows:

Age: 40 years

Blood pressure: 144/82 mmHg (not on treatment)

Total cholesterol: 10.3 mmol/L

HDL cholesterol: 1.2 mmol/L

Smoking status: Never smoked

You diagnose hypercholesterolaemia and complete the application form of his medical aid for chronic benefits. The Framingham risk is 6% for the next 10 years and the medical aid informs Mr Smith that he does not qualify for lipid-lowering medication.

The average age of death in untreated men with heFH is 43 years and Mr Smith clearly does need to be treated. The Framingham equation should never have been requested or performed. You inform the medical aid that Mr Smith has FH and must be treated and indicate that you are willing to take up the matter with higher authorities if treatment continues to be denied.

All FH patients require treatment; the question for the individual is not whether to treat but when to start treatment.

In adults, treatment should generally be initiated at diagnosis or very soon thereafter.

Statins have been shown to be safe in children in short-term studies, but no studies have addressed the question of the optimal age of treatment initiation. The decision to treat should be individualised, based on the child's family history (age of onset of IHD in family), the LDLC and the presence of other risk factors.² One also needs to consider the attitude of the child and parents to treatment and the likelihood that treatment will actually be taken. Depending on the circumstances, one may thus recommend starting treatment before the age of 10 in some, while waiting till late adolescence in others. Referring the family for an assessment at a lipid clinic can be helpful in deciding on treatment. Once the decision to treat has been made, statins rather than bile acid sequestrants (BAS, e.g. cholestyramine) should be prescribed. The latter used to be recommended as initial treatment for children because they are not absorbed systemically, but cholestyramine is less effective than statins and frequently causes nausea, bloating and constipation. This leads to poor compliance, and the child may develop an aversion to doctors and lipid-lowering treatment.

In general, there is no reason to advise against pregnancy or breastfeeding in women with FH. Statins are, however, not licensed for use during pregnancy and contraception

must be discussed with all potentially child-bearing female patients. Contraception should be reviewed at each follow-up visit. The contraceptive choice is based on standard indications and contraindications. Patients that wish to conceive should first stop lipid-lowering therapy and can then discontinue contraception two to three months later. Although BAS are theoretically safe during pregnancy, patients are generally not prescribed any lipid-lowering therapy while pregnant or breastfeeding. There is therefore also no need to monitor lipid levels routinely during pregnancy. In fact, documenting the physiological rise of LDLC during pregnancy may cause unnecessary anxiety. Statin therapy can resume once the infant has been weaned and contraception has been restarted.

Women who conceive inadvertently while on statins should discontinue the statin immediately and be referred for detailed foetal assessment. There are limited data on the safety of statins in pregnancy, but the available data do not suggest that the risk of malformations is markedly increased or that there is a specific pattern of foetal malformation with statin exposure.²

LDLC-lowering therapy

Statins are the lipid-lowering drugs of choice in patients with FH. They reduce LDLC very effectively and their safety and efficacy have been well documented. Because LDLC is so markedly elevated in FH, it is often difficult to reach the LDLC targets recommended by guidelines. However, one should aim to reduce LDLC by at least 50%.² This can usually only be achieved by using high-potency statins, such as atorvastatin or rosuvastatin. The top doses are frequently required, because doubling the statin dose only achieves a further 6% LDLC reduction.

Ezetimibe is a cholesterol absorption inhibitor that lowers LDLC by about 18–20% as monotherapy. The LDLC lowering achieved with ezetimibe is additive to that of statins. Ezetimibe is generally well tolerated and is thus useful as add-on therapy when LDLC levels remain high, despite maximal or maximally tolerated statin doses.

BAS can lower LDLC by up to 25%, but their usefulness is limited by their poor tolerability. They may also interfere with the absorption of other medications and have largely been superseded by ezetimibe, which has become the drug of choice when additional LDLC lowering is required.

Fibrates and nicotinic acid may be useful in carefully selected patients with additional lipid abnormalities, such as high triglycerides or low HDLC. The combination of a high-dose statin and a fibrate or nicotinic acid should only be initiated at specialist level.²

Patients with hoFH should be treated at lipid clinics. Conventional lipid-lowering therapy is only modestly

effective in hoFH, but some newer drugs are showing very promising results in clinical trials.

Treating the family

The pedigree is the starting point for family evaluation. The recommended screening strategy for FH is cascade testing: using the index patient as a starting point, other potentially affected relatives are screened. Screening is best done by genetic testing if the mutation is known. LDLC is used if the mutation has not been identified.² LDLC screening is easier and cheaper than DNA screening, but will misclassify some individuals with indeterminate LDLC values.

Screening a family successfully requires their co-operation. This is unfortunately not always given. Some of the problems encountered during screening include the following:

- Patients lose contact with their families: “Don’t know.”
- Contact may have been broken off deliberately: “Not talking to each other.”
- Patients may not want other family members to know that they have hypercholesterolaemia: “Don’t tell.”
- Family members may not want to face the possibility that they have an inherited disorder: “Not interested.”

Currently there is no systematic screening strategy for FH in South Africa and screening is opportunistic. The Netherlands has a highly developed screening system based on DNA testing and a central, nationwide register. Many previously undiagnosed patients have been identified using this approach.

Starting a family

The potential risk of having a child with hoFH should be discussed with all heFH patients planning to start a family. The risk is particularly high if the partner originates from a founder population. A heterozygote that has a child with a partner from a founder population has a 1:400 chance of having a homozygous child, based on a mutation prevalence of 1:100 in the founder community and a 1:4 chance that two heterozygotes will have a homozygous child. This is a substantial risk that one should not ignore.

Conclusion

The diagnosis of FH should be considered in all patients with severe LDLC hypercholesterolaemia not attributable to other causes. Family screening is possible, and effective intervention is available. Making the diagnosis early will prevent many premature deaths. The treatment of FH is not difficult and funding is often the largest obstacle to overcome initially, followed by the challenge of keeping the patient on treatment.

References

1. Steyn K, Goldberg YP, Kotze MJ, et al. Estimation of the prevalence of familial hypercholesterolaemia in a rural Afrikaner community by direct screening for three Afrikaner founder low density lipoprotein receptor gene mutations. *Hum Genet* 1996;98(4):479–84.
2. Wierzbicki AS, Humphries SE, Minhas R. Familial hypercholesterolaemia: summary of NICE guidance. *BMJ* 2008;337:a1095.
3. Firth JC. Familial hypercholesterolaemia – the Cape Town experience. Cape Town: University of Cape Town: 2005.
4. Risk of fatal coronary heart disease in familial hypercholesterolaemia. Scientific Steering Committee on behalf of the Simon Broome Register Group. *BMJ* 1991;303(6807):893–6.
5. Brown MS, Goldstein JL. A receptor-mediated pathway for cholesterol homeostasis. *Science* 1986;232(4746):34–47.
6. Myant NB, Forbes SA, Day IN, Gallagher J. Estimation of the age of the ancestral arginine 3500 --> glutamine mutation in human apoB-100. *Genomics* 1997;45(1):78–87.
7. Abifadel M, Rabes JP, Devillers M, et al. Mutations and polymorphisms in the proprotein convertase subtilisin kexin 9 (PCSK9) gene in cholesterol metabolism and disease. *Hum Mutat* 2009;30(4):520–9.
8. Cohen JC, Boerwinkle E, Mosley TH, Jr., Hobbs HH. Sequence variations in PCSK9, low LDL, and protection against coronary heart disease. *N Engl J Med* 2006;354(12):1264–72.
9. Arca M, Zuliani G, Wilund K, et al. Autosomal recessive hypercholesterolaemia in Sardinia, Italy, and mutations in ARH: a clinical and molecular genetic analysis. *Lancet* 2002;359(9309):841–7.
10. Ceska R, Vrablik M, Horinek A. Familial defective apolipoprotein B-100: a lesson from homozygous and heterozygous patients. *Physiol Res* 2000;49 Suppl 1:S125–S130.
11. Zhao Z, Tuakli-Wosornu Y, Lagace TA, et al. Molecular characterization of loss-of-function mutations in PCSK9 and identification of a compound heterozygote. *Am J Hum Genet* 2006;79(3):514–23.
12. Fouchier SW, Defesche JC, Umans-Eckenhausen MW, Kastelein JP. The molecular basis of familial hypercholesterolemia in the Netherlands. *Hum Genet* 2001;109(6):602–15.
13. Dietary supplementation with n-3 polyunsaturated fatty acids and vitamin E after myocardial infarction: results of the GISSI-Prevenzione trial. Gruppo Italiano per lo Studio della Sopravvivenza nell’Infarto miocardico. *Lancet* 1999;354(9177):447–55.